

DATRON MLCube



DATRON MLCube

Milling, drilling and engraving

The DATRON MLCube is the best choice for cost-effective sheet machining, for example, for the production of front panels, housings, profiles and other aluminium workpieces milled in nested form.

Other non-ferrous metals or composite materials can also be processed most efficiently with the MLCube. Its short setup times and its ability to use different clamping techniques simultaneously, its very low power consumption and its excellent price-performance ratio – even for low production volumes – provide long-term and extremely high profitability.

Your benefits at a glance:

- Extremely large working area requiring little floor space.
- New vacuum clamping technology with the possibility of electrically enabling/disabling different segments.
- Available with table cutout for vertical clamping technology, appropriate for machining high components (optional).
- Contour smoothing package PerfectCut for fast, accurate and contour faithful HSC milling with excellent surface quality: your machine is more powerful and stays “fit” longer, even in cases of high-volume production (optional).
- New chip carriage design with allocation to multiple containers (stackable) to promote work ergonomics.

DATRON MLCube

Highlights of the MLCube

- High dynamics through optimised control and mechanical construction designed for acceleration and rigidity
- Very high cutting performance using smallest tools due to the high-speed precision high-frequency spindles with up to 60,000 rpm and outputs from 0.6 kW to 3.0 kW
- Rigid, low-vibration machine construction optimised for excellent surface finishes when using FEM for machining.
- High precision due to its high-quality linear guides, ball screw spindles, HSK-E 25 tool insert (optional) and precisely-crafted structural elements

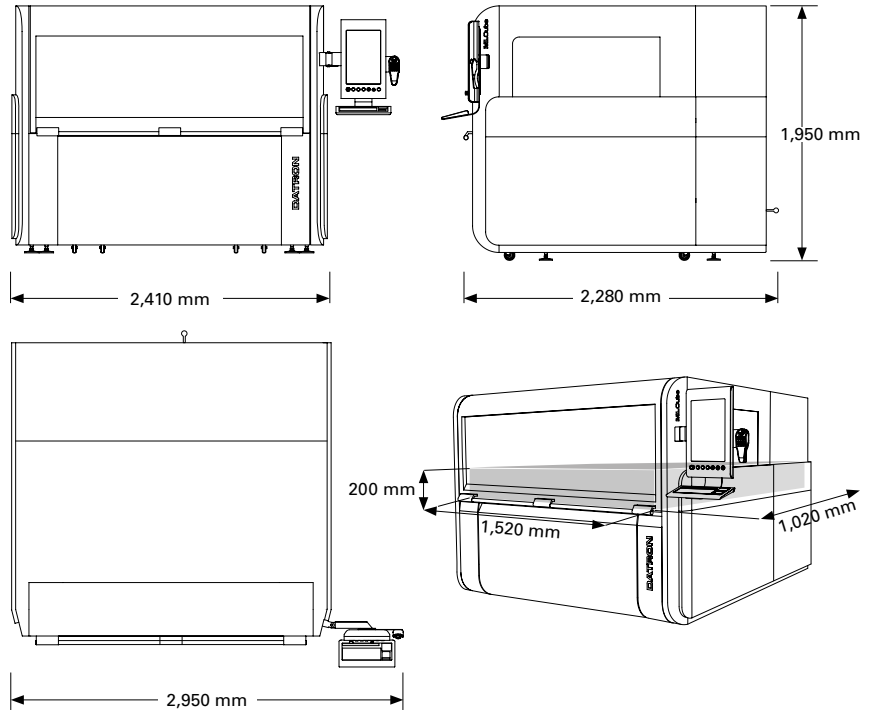

Status display by means of signal LEDs integrated into the operating terminal and the portal to display machine status (optional).



Precision spindle with a concentricity better 2 µm and HSK-E 25 tool holding fixture (optional).



XYZ measuring system integrated: Measuring functions and very easy-to-use-material/tolerance compensation (optional).



Saves resources: Minimum quantity lubrication from 30 ml/hour. Minimal cleaning costs (optional).



up to 60.000 rpm
High cutting performance with small tools. High dynamic HSC control system.



Precision ball-screw spindles and linear guides from leading suppliers. Brushless direct drives in the X/Y axes.

Technical Data	DATRON MLCube
Machine table	Solid polymer concrete table with steel column, extremely rigid portal design with double-sided Y drive with covered guides
Traverse path (X x Y x Z)	1,520 mm x 1,150 mm x 245 mm; with tool changer 1,020 mm in Y
Portal passage	200 mm
Installation dimensions without operating terminal (W x D x H)	2,410 mm x 2,280 mm x 1,950 mm
Conical holding fixture integrated into the table	✓
Fast digital servo control with Microsoft® Windows® control computer	✓
Easy-to-use hand-held control unit	✓
Drive system: Brushless servo motors with absolute encoders, ball-screw spindle for each axis	✓
Minimal quantity lubrication	✓
Machining spindle	Precision high-frequency spindles from 0.6 kW to 3.0 kW with up to 60,000 rpm
Tool changer with integrated tool length sensor	5-fold tool changer with HSK (up to 36-fold) 15-fold tool changer with direct shank (up to 45-fold)
Feed	up to 20 m/min
Positioning feed	up to 20 m/min
Weight	approx. 2,500 kg
Article Number	0A03300A/B

The information in this brochure contains current descriptions or performance features which are subject to change due to further development of the products. The descriptions and performance features are binding only if they are expressly agreed in writing at the time of conclusion of the contract.

DATRON_MLCube_EN_ID_030913